

KATIE SIDE FOLDING TABLE

RG63SFT

MARCH 2020

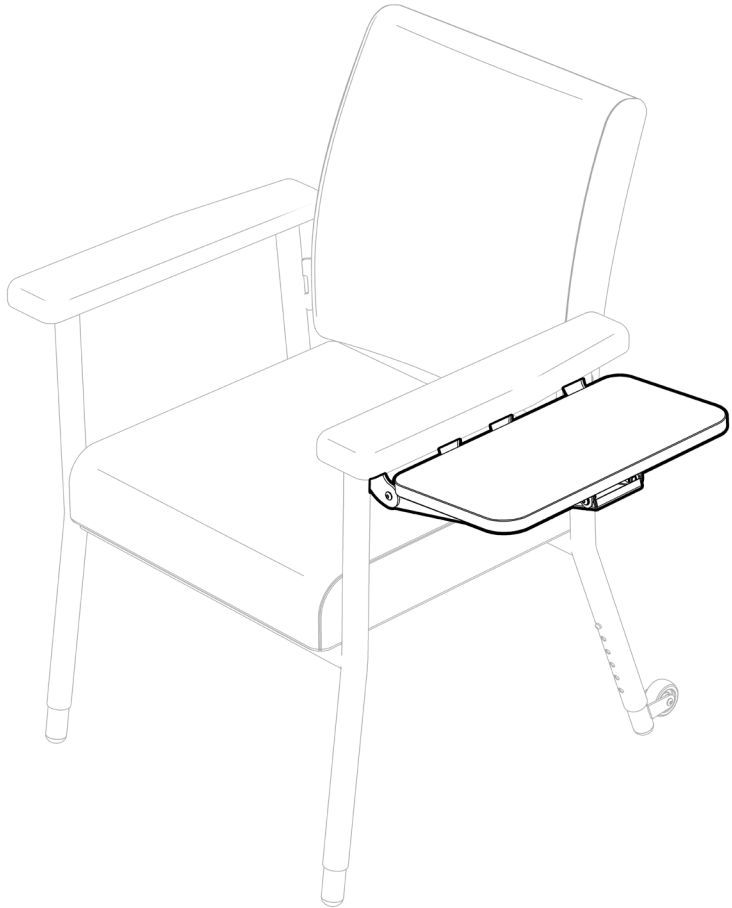

USER MANUAL

Please read and keep these instructions



REDGUM Brand owns the **copyright** to the KATIE SIDE FOLDING TABLE user manual. Any information contained in this user manual shall not be photocopied, reproduced or translated into any other languages without the prior written consent of REDGUM Brand.

REDGUM Brand strives to provide the highest quality products possible. Products are subject to change without notice.

© Copyright **REDGUM Brand** 2020



REDGUM Brand is part of **FOR-DE Group Pty Ltd**

redgumbrand.com.au

CONTENTS

1. **INTRODUCTION** - INTENDED USE
2. **PRODUCT OVERVIEW** - FEATURES / SPECIFICATIONS
3. **ASSEMBLY** - UNPACK and INSPECT SUPPLIED PARTS
4. **ASSEMBLY** - ATTACH SIDE FOLDING TABLE TO KATIE CHAIR
5. **USAGE GUIDELINES** - SIDE FOLDING TABLE ADJUSTMENT
6. **USAGE GUIDELINES** - DO's + DON'Ts
7. **PRODUCT CARE** - INSPECTIONS / CLEANING
8. **WARRANTY**

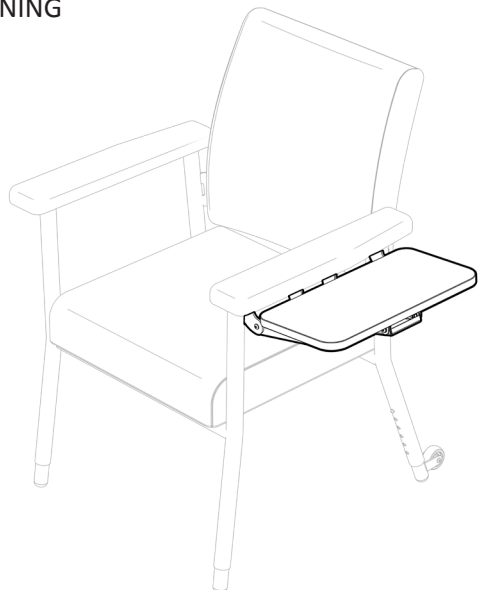

INTRODUCTION

Thank you for purchasing this quality **REDGUM Brand** product.

If you have any issues or questions about the KATIE Side Folding Table please contact your supplier or REDGUM Brand direct:

T: +61 8 9248 4180

F: +61 8 9248 9452

E: sales@for-de.com.au

A: 1 Business Way, Malaga Western Australia 6090

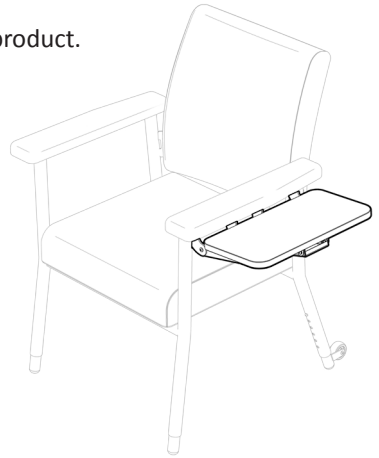

INTENDED USE

This product has limitations and should be used in accordance to these guidelines. Failure to follow these guidelines may result in damage to the product and injury to the user. It is the responsibility of the user to ensure the suitability of this product for its intended use. The user should consult their appropriate healthcare professional if unsure of the correct product usage for their unique circumstances.

The KATIE Side Folding Table has been designed to **ONLY** fit onto the KATIE High / Low Back Chair range.

Only use your KATIE Side Folding Table for the purpose for which it is intended, which is as a side table for lightweight items ie. drink bottle / phone / book etc

IMPORTANT NOTE: Do not sit or rest someones body weight on the folding table!

IMPORTANT NOTE

This equipment **MUST** be fitted onto a Katie Chair by a competent person.

It is recommended that a second person is used to assist with holding the Side Folding Shelf in place whilst being fixed into position.

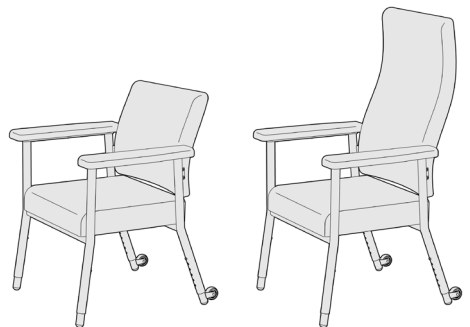

PRODUCT OVERVIEW

FEATURES

Folding Side Table for the:
Katie High back Chair
Katie Low back Chair

Can be fitted on left or right side of Katie Chair

Ideal for holding small items
(Drink bottle / Phone / Book / TV remote etc)

Hard wearing laminated platform
with plastic edging

400 x 200mm work area

Table folds down when not in use

Easy to engage / disengage folding shelf

Large user friendly release lever

Strong lightweight construction

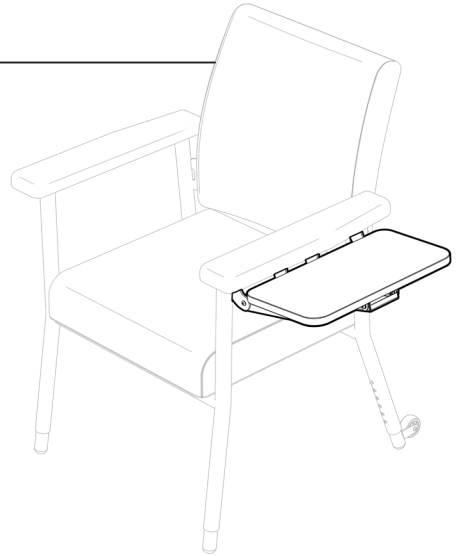

SPECIFICATIONS

Dimensions:

Platform Width: **200mm**

Platform Depth: **400mm**

Product Weight: **3kg**

Maximum Weight Loading: **10kg - evenly distributed**

Please contact **REDGUM Brand** if you would like any further information on your KATIE Side Folding Table.

ASSEMBLY- UNPACK and INSPECT SUPPLIED PARTS

Ensure you have been supplied with the following parts:

PARTS:

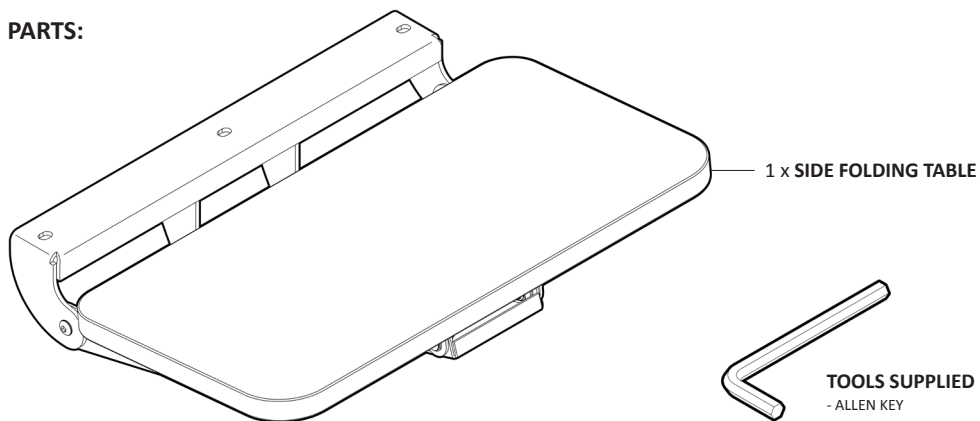

IMPORTANT NOTE

Check the product for any visible damage. If you see any damage or suspect a fault, **DO NOT USE YOUR PRODUCT** and contact your supplier for support.

The Side Folding Table bolts onto the underside of preferred armrest of a Katie Chair.

Position the Katie Chair on its back to access the underside of the armrest.

Determine which side the Side Folding Table is to be located.

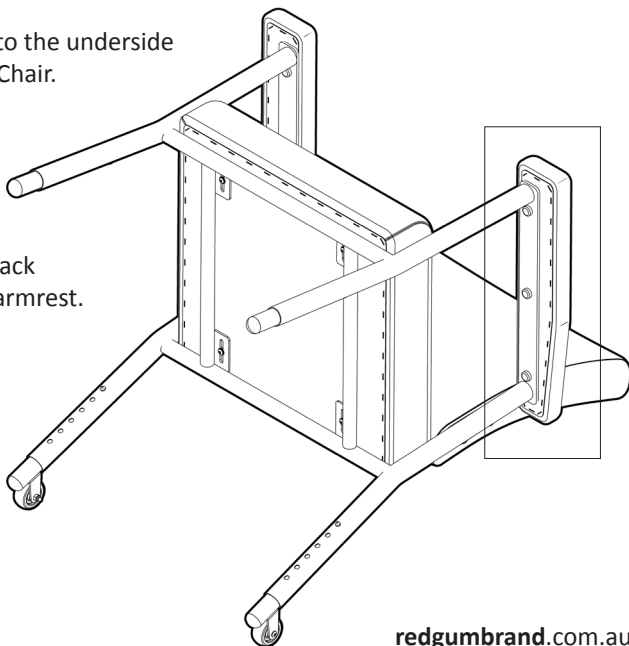

3.

redgumbrand.com.au

ASSEMBLY - ATTACH SIDE FOLDING SHELF TO KATIE CHAIR

Before the Side Folding Table can be installed the fixings holding the armrest on need to be removed.

1. Open the cover cap
(Use a blade or small flat head screw driver)

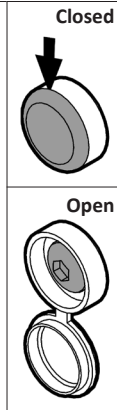

2. Using the Allen Key provided remove all 3 screws.
3. With the assistance of another person - line up the holes in the Side Folding Table mounting bracket with the holes on the armrest mounting plate and armrest.
4. Using the Allen Key provided fasten the Side Folding Table in place with the 3 screws.
5. Close cover caps.

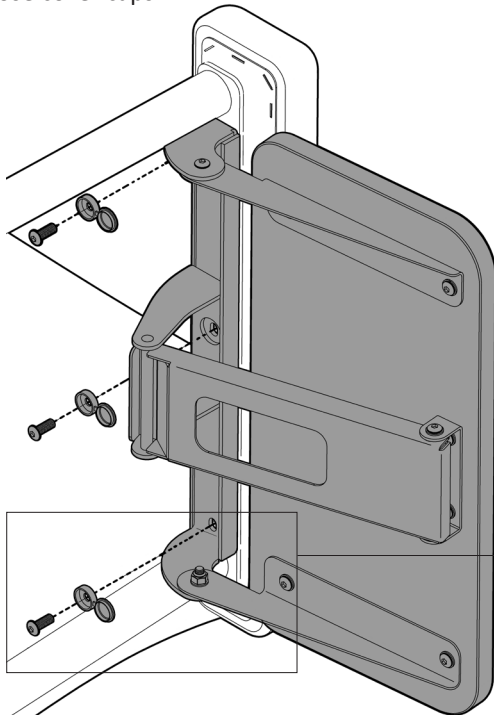
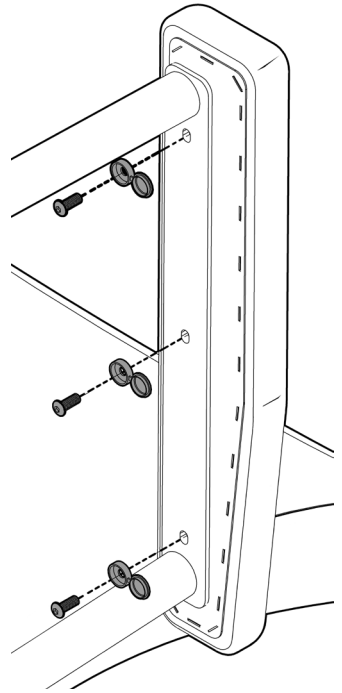

4.

Close caps once screw is in place

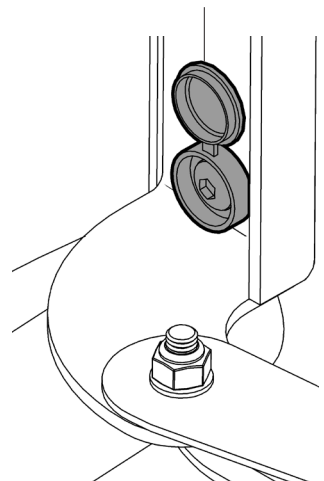

USAGE GUIDELINES - SIDE FOLDING TABLE ADJUSTMENT

The KATIE Side Folding Table can be set in UP position for use as a table or Down for when not in use.

To lower the Side Folding Table down:

1. Using your hand as shown below slightly lift the side table up
2. Push the release lever up with your fingers
3. Slowly guide the table into the down position.

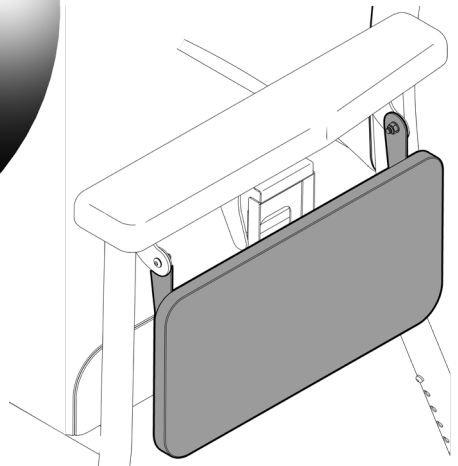
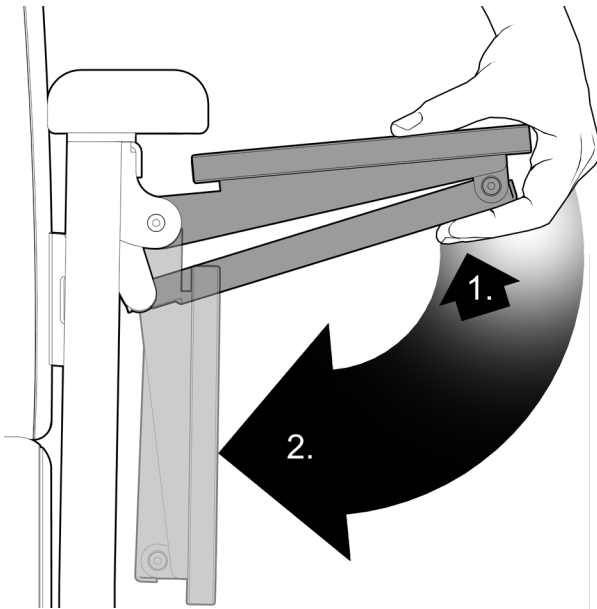
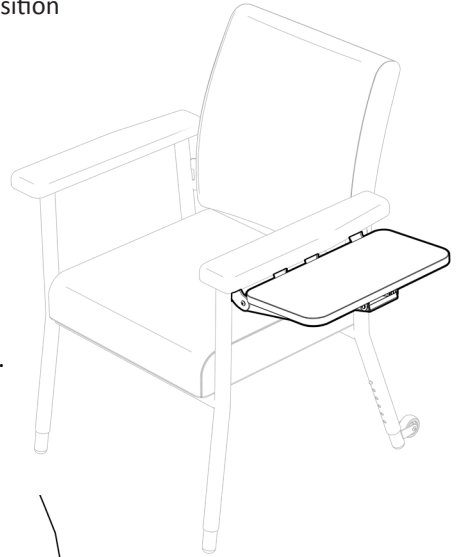

To raise the Side Folding Table:

- Simply lift the table up until you hear a 'Click'
- Slightly lower to table down until it rests in the up position

5.

USAGE GUIDELINES - DO's + DON'TS

Please follow these guidelines to get the optimal benefit from your KATIE Side Folding Table.

Failure to follow these guidelines may result in damage to the product and put the user at risk.

The KATIE Side Folding Table is designed to take **10kg Maximum Load** (evenly distributed).

This product and the Katie Chair range is designed for **INDOOR USE** only.

Do not lean on the Side Folding Table.

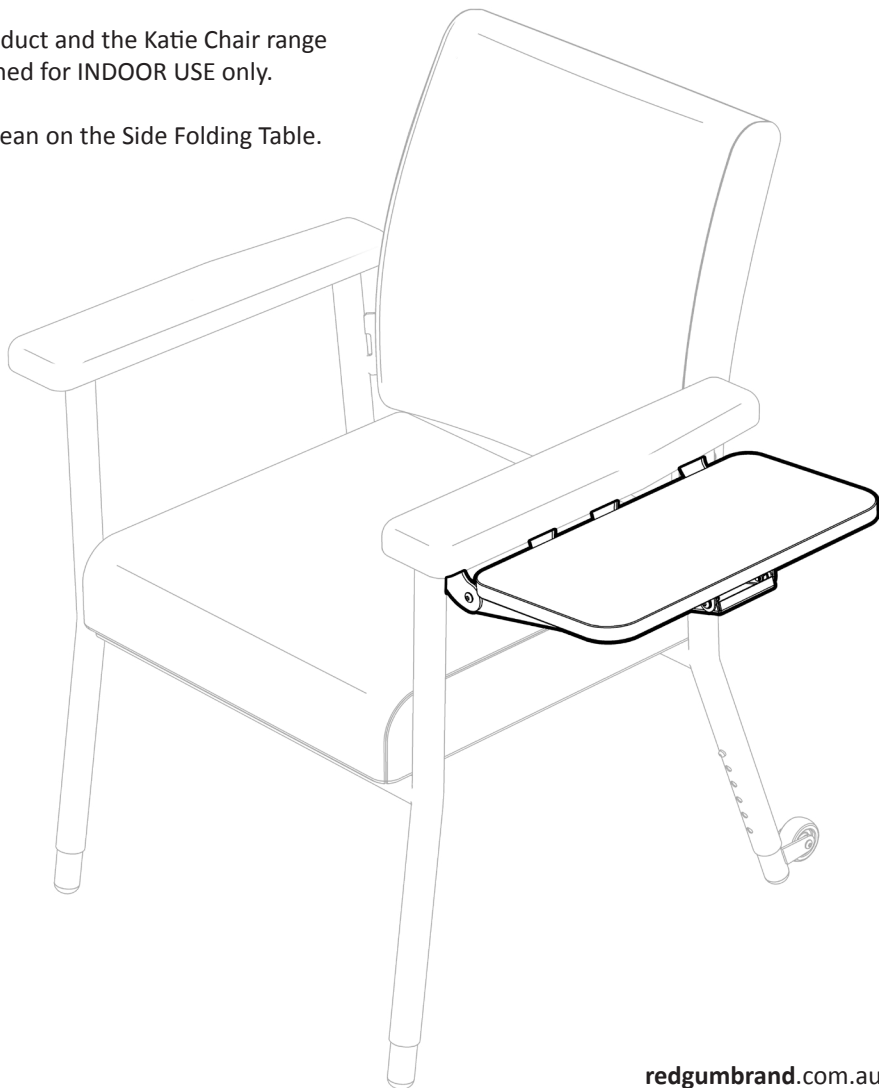

PRODUCT CARE - INSPECTIONS / CLEANING

INSPECTIONS

We suggest that you visually check your KATIE Side Folding Table periodically for signs of damage or wear prior to use. Overall check that no components are loose or worn.



Withdraw the KATIE Side Folding Table immediately if you suspect damage or any other fault. If in any doubt, please do not issue or use, but immediately contact your supplier for service support.

IMPORTANT NOTE

Do not fit any parts or accessories to your KATIE Side Folding Table that are manufactured by another company. To do so will void your warranty and may seriously compromise your safety.

CLEANING

Clean your KATIE Side Folding Table using a non-abrasive cleaner or mild detergent with a soft cloth.

Abrasive cleaners or abrasive cleaning pads could damage the KATIE Side Folding Table and should not be used.

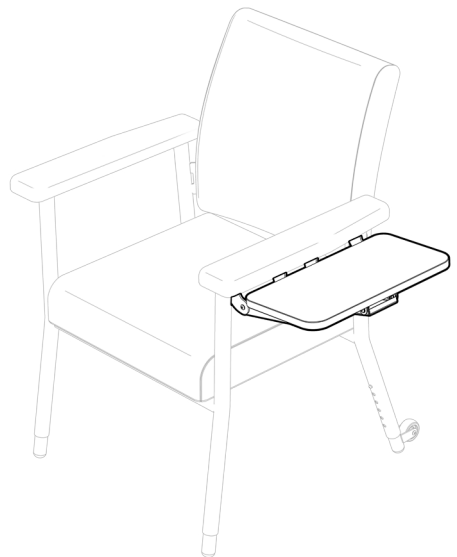

WARRANTY

Your REDGUM Brand:

RG63SFT - KATIE SIDE FOLDING TABLE

is covered by a **12 Month Warranty** from the date of purchase.

If the product has any manufacturing faults during this period contact the place of purchase for assessment. Failures as a result of **ACCIDENTAL MISUSE, MODIFICATION OR WEAR AND TEAR ARE NOT COVERED BY THIS WARRANTY.**

Our goods come with guarantees that cannot be excluded under the Australian Consumer Law. You are entitled to a replacement part for a major failure and for compensation for any other reasonably foreseeable loss or damage. You are entitled to have the goods repaired or replaced if the goods fail to be of acceptable quality and failure does not amount to major failure.

If you have any issues or questions about your KATIE Side Folding Table please contact your supplier or REDGUM Brand direct on:

T: +61 8 9248 4180

F: +61 8 9248 9452

E: sales@for-de.com.au

A: 1 Business Way, Malaga

Western Australia 6090

**Please keep this User Manual
in a safe place for future reference.**

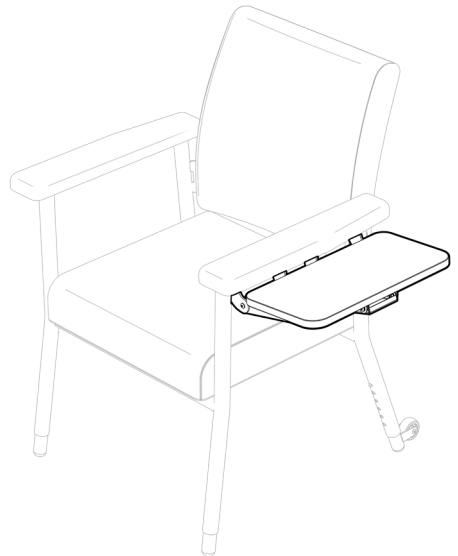

DISTRIBUTOR:

REDGUM BRAND
*Daily Living and
Lifestyle Products*



Proudly Australian Owned and Operated

redgumbrand.com.au